

Railway Signalling since the birth to ERTMS

Maurizio Palumbo

November 2013

railwaysignalling.eu, Italy

maur.palumbo@railwaysignalling.eu

ABSTRACT

Railway signalling can be defined as all systems used to control railway traffic safely, essentially to prevent trains from colliding. Over the years knowledge and technology able to satisfy this issue have been implemented.

After a long period during which each European nation used its own system (with the consequent absence of interoperability among them), ERTMS/ETCS is currently the most common signalling system adopted in Europe for the development of High Speed Lines. It can ensure high performances regarding interoperability, safety, cost, accessibility, and maintenance. These aspects can guarantee a fast growth of the rail transportation in Europe, something fundamental for integration within the continent.

KEYWORDS: Railway Signalling, ERTMS, ETCS, ATP, GSM-R, High Speed line

1. INTRODUCTION

Since the birth of railways, there has always been the need to develop applications able to satisfy the railway traffic control. For this purpose, state of art of signalling has followed a continuous improvement, starting from hand signals until to the most modern technologies for train separation.

Over the years, in Europe have been developed and operated a lot with the consequent absence of interoperability among different countries.

In the modern era, where the labor market goes beyond national borders, different national ATP systems and the consequent absence of interoperability was an important limit for the European Integration. This is one of the reasons of the birth of ERTMS programme, core of this paper.

It is composed essentially by the command and control system ETCS and the radio communication network GSM-R.

The analysis of the ERTMS main features shows how the whole architecture ensures, in addition to interoperability, different benefits regarding safety, cost, accessibility, and maintenance.

Thanks to these tangible advantages, ERTMS is currently the most used technology for railway signalling in Europe and it's on a launching ramp in the rest of the world.

2. SOME HISTORY ABOUT RAILWAY SIGNALLING

All railway safety systems, starting from those used since the birth of the first railroads in Europe, to the most advanced systems nowadays used, share a basic concept:

Trains cannot collide with each other if they are not permitted to occupy the same section of track at the same time. [3]

For this reason, railway lines are divided into sections, known as blocks (or block sections). In a common operative mode, only one train is permitted in each block at a time.

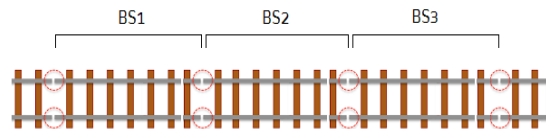

Figure 1 - Railroad divided in Block Sections

2.1 EVOLUTION OF SIGNALLING BLOCK SYSTEMS

In the early days of railways (1850), men (train dispatchers) were standing at intervals (blocks) along the line with a stopwatch and they used hand signals to inform train drivers that a train was going to pass.

In order to help the staff, mechanical semaphores were introduced at the turn of the century (1900).

With the invention of the telegraph and then of the telephone, it became possible for the staff at a station to send a message (first a certain number of rings on a bell, then a telephone call) to confirm that a train had passed and that a specific block was finally clear. About in 1930 the first optical signals were introduced. The whole system was called *phone block system*. When *fixed mechanical signals* began to replace hand signals from the 1930s, the *semiautomatic block* was born.

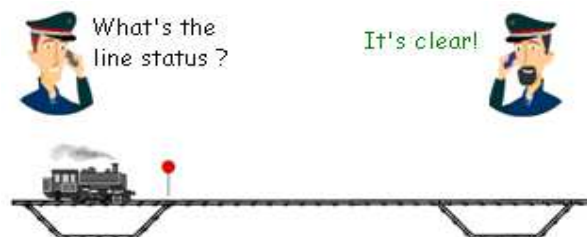

Figure 2 - Phone Block System

Nowadays, railway signalling is based on *automatic blocks*, which does not require manual intervention.

A line equipped with automatic blocks (*interlocking*) is divided into sections of length not shorter than the braking distance of the faster train running on the route.

The function of detecting the presence or transit of the vehicles in a particular section can be realized through two different equipments:

1. An electromagnetic device (relay) realizes the *track circuit*, an electrical circuit that used as conductor, the two rails of the track. The transit of a vehicle on the track causes the electrical contact on the two rails, so the circuit is closed, the relay is characterized by zero current and the block signal is set at danger (or occupied).

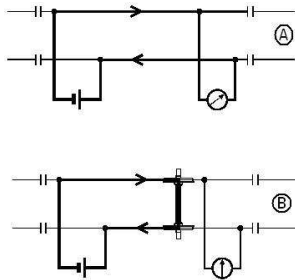

Figure 3 - Free (A) and occupied (B) track circuit

2. In the most modern railway lines, at the start and the end of each block section, equipments called *Axle Counter* are placed. It acts as a counting head, detecting all the axles of rolling stock travelling on a track and also their direction of travel, using two electronic wheel sensor systems.

By comparing the result for the axles counted in with the result for those counted out, it is possible to know the status of the track section (Free or occupied). Referring to Figure 4, until the number of axles counted by Ax2 (train exiting from TS1) is not equal to that counted by Ax1 (train entering in TS1), then the track section TS1 shall be considered "occupied".

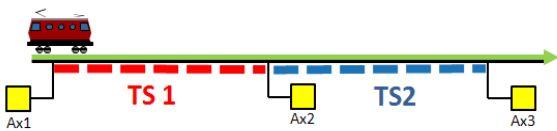

Figure 4 - Axle Counters for track occupation detecting

2.2 ATP SYSTEMS

At the beginning of 80s, upgraded rail signalling systems were introduced in Europe, in order to increase the railway safety. They were already able to constantly monitor the speed of the train. They're called *ATP* (Automatic Train Protection) systems. First ATP systems used a target speed indication and audible warnings to advise the driver if the train passed a red (danger) signal or exceed a speed restriction. In these cases, the system applied an automatic brake if the driver fails to respond to the warnings [3].

One of the key principles of an ATP system is the *braking model* concept, a mathematical model applicable to any land vehicle with a constrained guide.

It allows predicting the maximum safe speed of the vehicle, starting from the following data:

- Target distance (a potential obstacle during the route)
- Current speed
- Physical characteristics of the vehicle

Once known the braking pattern, it's easy to determine what the maximum speed is at which the vehicle can travel, so that it can stop safely before the target/danger point [8].

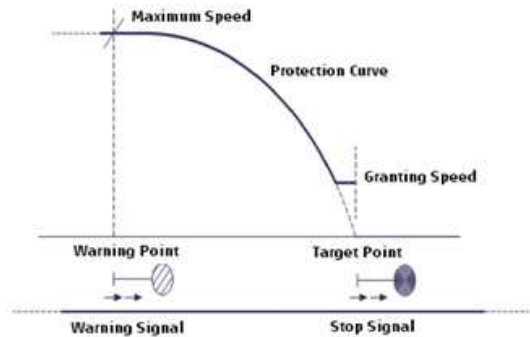

Figure 4 - Axle Counters for track occupation detecting

2.3 FROM NATIONAL ATP SYSTEMS TO ERTMS/ETCS

Over the years, in Europe have been developed and operated a lot of different ATP systems, according to the different national requirements, technical standards and operating rules.

Obviously, in the modern era, where the labor market goes beyond national borders, the independent development of these national systems was an important limit for the European Integration.

Following the decision taken by the European Transport minister in December 1989, the EU embarked upon a project to analyze the problems relating to signalling and train control. At the end of 1990, the *ERRI* (European Institute of Railway Research) began to think to develop a common interoperable ATP system, which could be adopted in all European countries [9].

ERTMS/ETCS has been chosen as the international command-control and signalling system. Thanks to these standardizations, from the beginning of the 21s century interoperability of the European rail network's guaranteed.

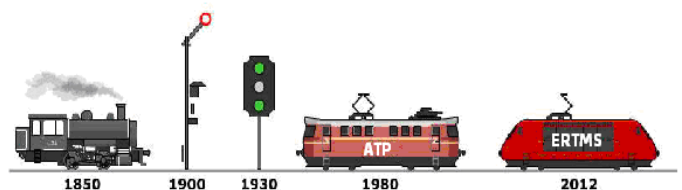

Figure 5 - from National ATP to ERTMS/ETCS

3. ERTMS PROGRAMME

ERTMS is an international standard programme created to develop a common interoperable platform for railways and signalling systems.

Interoperability is achieved when a system is able to operate together with other systems of different origins with predefined limits [1].

The main objectives of interoperability are based on the need to simplify, improve and develop international railway

transport services, contribute towards gradually creating an open and competitive domestic market for the supply of railway systems and construction, renewal, restructuring and operative services, and establish standardised European procedures for assessing conformity with interoperability requirements.

For this purpose, the essential activities for achieving interoperability were the definition of a set of sub-system and components of the platform, specifying their essential requirements and interfaces by developing functional and technical specifications.

Then, at the end of 1993, the EU council issued an Interoperability Directive and a decision was made to create a group of railway expert called *ERTMS Group*, consisted originally of *DB*, *FS* and *SNCF*, but later joined by other railway European companies. The purpose was realizing a structure in order to define the *TSI* (Technical Specification for Interoperability) [9].

In the summer of 1998, the *UNISIG* union, comprising the European Signalling companies *Alcatel*, *Alstom*, *Ansaldo Signal*, *Bombardier*, *Invensys Rail* and *Siemens*, was formed to finalize the TSI of the ERTMS project.

The *command and control* system chosen is a standardized, interoperable ATP/ATC system, called *ERTMS/ETCS*, or simply *ETCS*.

In order to allow the communication between trains, trackside and railway regulation control centres, the sub-system chosen is *GSM-R*, the international wireless communications standard for railway communication and applications. For this reason, ERTMS programme can be defined as the combination of ETCS and GSM-R subsystems.

3.1 ETCS

ETCS is divided into different functional levels. The definition of levels depends on how the railroad is equipped and the way through information are transmitted to the train.

3.1.1 ETCS LEVEL 0

One of the best advantages of the adoption of the ERTMS/ETCS standards is the absence of lateral signals. Anyway, when an ETCS vehicle is used on a *non-ETCS* route without a trainborne STM (Specific Transmission Module), the trainborne equipment monitors the train only regarding the maximum speed. Furthermore, the train driver has to observe the trackside signals [1].

3.1.2 ETCS LEVEL 1

ETCS Level 1 is a cab signalling system that can be superimposed on the existing signalling system, i.e. leaving the fixed signal lateral system (national signalling and track-release system) in place. *Eurobalise* radio beacons pick up signal aspects from the trackside signals via signal adapters and telegram *LEU Encoders* and transmit them to the train as a *Movement Authority* (permission to cross one or more block sections) together with route data at fixed points [12].

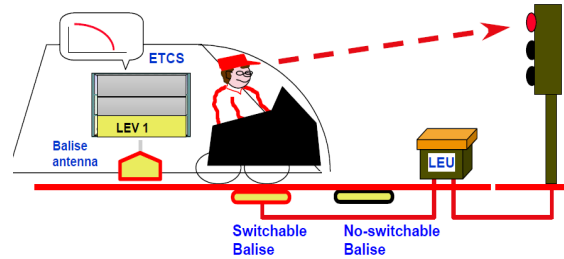

Figure 6 – ETCS Level 1

The on-board computer continuously monitors and calculates the maximum speed and the braking curve from this data. Because of the spot transmission data, the train must travel over the Eurobalise beacon to obtain the next movement authority [11].

The ETCS Level 1 constitutes a *spot or semi-spot ATP/ATC* with interoperable Cab Signalling and fixed block. This system is installed on Austrian High Speed lines and in some parts of the British and Spanish lines.

3.1.3 ETCS LEVEL 2

ETCS Level 2 is a digital radio-based signal and train protection system. *Movement authorities* are given to the driven in order to allow the train to move itself on the track and the most of the signals are displayed in the trainborne cab, substituting the lateral traditional signals. Thus, apart from a few *indicator panels* like overriding and border signals (these panels mark the extreme points of a block sections or of the ETCS L2 area) it is therefore possible to work without a lateral trackside signalling [1].

The train separation systems use the term *virtual signals*, because the concept of a traditional railway signal, like fixed light lamps, is physically moved to the train DMI (Driver Machine Interface).

However, with track-release signalling devices like *track circuits*, the train integrity supervision still remains in place at the trackside. All trains automatically report their exact position and direction of travel to the *RBC* (Radio Block Centre) at regular intervals, through the *GSM-R* network [1].

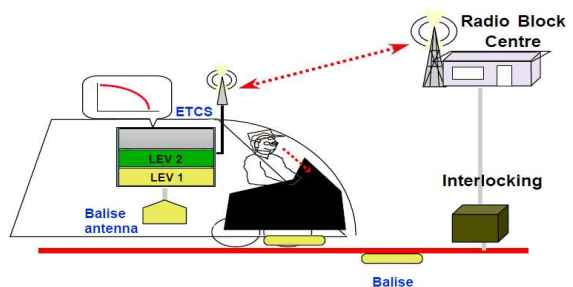

Figure 7 – ETCS Level 2

The *Eurobalises* are used at this level as *passive positioning beacons* or *electronic milestones*. Between two positioning beacons the train determines its position via sensors. The positioning beacons are used in this case as reference points for correcting distance measurement errors. The on-board computer continuously monitors the transferred data and the maximum permissible speed.



Figure 8 – Full-Duplex transmission via GSM-R

The ETCS Level 2 constitutes a *continue ATP/ATC* system with interoperable Cab Signalling and fixed block sections. This system is installed on the Italian HS lines Turin-Novara, Bologna-Florence and Rome-Naples.

3.1.4 ETCS LEVEL 3

ETCS Level 3 provides an implementation of full radio-based train spacing. Fixed track-release signalling devices are no longer required.

As with ETCS Level 2, trains find their position themselves by means of positioning beacons and via sensors and must also be capable of determining train integrity on-board to the very highest degree of reliability. The route is thus no longer cleared in fixed track sections. In this respect ETCS Level 3 departs from classic operation with fixed intervals, because it calculates safe distance between two trains [1].

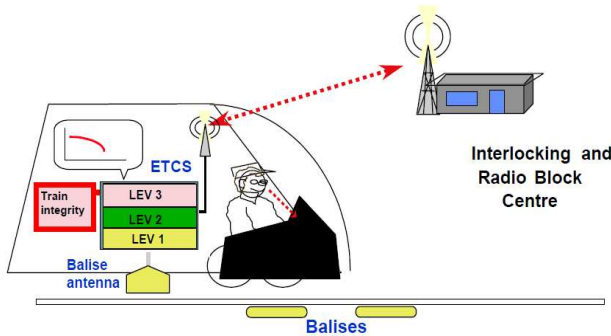

Figure 9 - ETCS Level 3

A movement authority is given on the information relating to the position of the train, based on the actual distance of a train from the next. This solution called absolute braking distance spacing or moving block, ensures a greater exploitation of the capacity of the line as it reduces the granularity of the spacing. Level 3 is currently under development.

3.2 GSM-R

GSM-R is the mobile communications system used exclusively in the railway sector.

With the GSM-R the railway infrastructure and its staff are equipped of a mobile radio system which can meet in an efficient and integrated, on a national scale, all the communication needs and data communications related with rail operations.

The GSM-R allows a constant contact between the crew and the ground (service communications and emergency management) for the exchange of data between trackside and on-board systems, by establishing a circuit-switched connection.

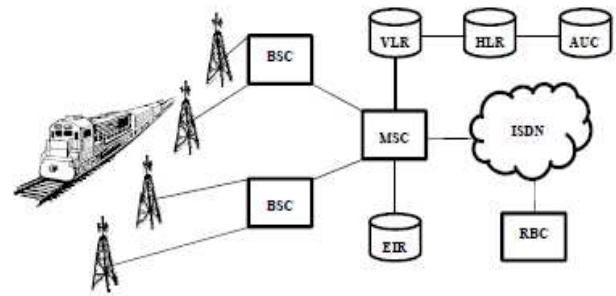

Figure 10 – GSM-R simplified infrastructure

GSM-R was standardized for the frequency bands of 876 MHz up to 915 MHz regarding the uplink between the mobile station (MS) and the base transceiver station (BTS) and 921 MHz up to 960 MHz regarding the downlink transmission.

This is realized by very small mobile cells with a maximum radius of 2-3 km and nearly a constantly line of sight connection (LOS) between the MS and the BTS. [16]

There to say that, even this technology is currently the ones used in the totality of ERTMS lines in Europe, researchs about the communication issues related to rail transport pushed all ERTMS stakeholders to consider alternative technical solutions, in order to increase the efficiency. For more detailed information, see Appendix A.

3.3 Implementation in Europe

The *High Speed* project began in 1991 as a *Turnkey project*, i.e.: a general Contractor is responsible for building the infrastructure and installing the technological system on each specific section. To maintain the technological uniformity on the work performed by each General Contractor on each *High Speed* Line section, the technological system were built by a technological consortium, responsible for supplying the technological and signalling system for all the HS sections [1].

A railway line may be considered *High Speed* if running trains reach at least a top speed of 200km. As of 2013 the maximum commercial speed is about 300 km/h for the majority of installed systems, but in some parts of Europe a train running on a HS line can reach the maximum speed of 350 km/h. Spain (3800km), France (2000km), Germany (1600km) and Italy (1000km) are currently the most equipped states.

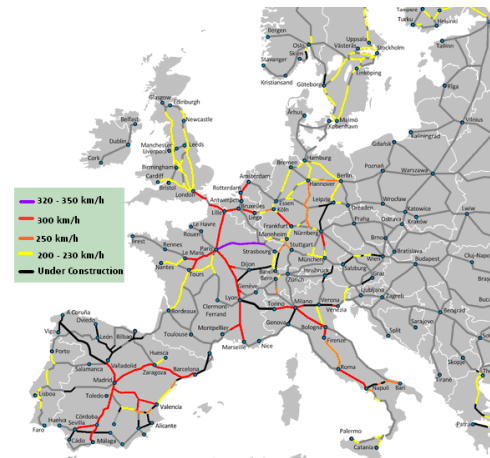

Figure 11 – ERTMS European Rail Network

3.4 Benefits of ERTMS

Compared with the traditional signalling systems, ERTMS is clearly more flexible and advanced with regard to conveying information [13]. There are also other advantages of implementing the ERTMS, which can be divided in the following categories:

1. Safety
 - Constant speed monitoring
 - Signals received in the cabin crew
 - TSR (Temporary Speed Reductions) sent to the network
2. Cost
 - No or reduced number of physical signals
 - Fewer track magnets with cable connections
3. Accessibility
 - Faster error recovery with reduced number of systems
4. Interoperability
 - Standardised architecture and information
 - Uniform technical interfaces between sub-systems
5. Maintenance
 - Standardised systems
 - Fewer critical safety interfaces
 - Several suppliers on the market (Competition)

4. CONCLUSION

It is clear that ERTMS offers as tangible benefits as the number of European (and Extra-European) countries have adopted it.

The wide competition on the rail market ensures continuous improvements by the most accredited rail suppliers and a reduced cost. This aspect can guarantee a fast growth of the rail transportation in Europe, something fundamental for integration within the continent. Work in progress for United States of Europe!

5. NOMENCLATURE

ATC	Automatic Train Control
ATP	Automatic Train Protection
BTS	Base Transceiver Station
DMI	Driver Machine Interface
ERTMS	European Railway Traffic Management System
ETCS	European Train Control System
GPRS	General Packet Radio Service
GGSN	Gateway GPRS Support Node
GSM-R	Global System for Mobile Communication - Railway
HS	High Speed
MS	Mobile Station
QoS	Quality of Service
STM	Specific Transmission Module
TS	Track Section
TSR	Temporary Speed Restriction
SGSN	Serving GPRS Support Node

6. REFERENCES

- [1] *ETCS – Development and implementation in Italy* - F. Senesi, E. Marzilli
- [2] *The Core of ATP* - Data Engineering - W. Kaiser, S. Nielson
- [3] http://en.wikipedia.org/wiki/Railway_signalling

- [4] *ETCS Implementation Handbook* - Olivier Leveque
- [5] *Increase of efficiency in wireless train control systems (ETCS L2) by the use of actual Packet-Oriented Transmission Concepts* - Institute of Communications Technology - Hannover, Germany
- [6] *ERTMS/ETCS System Requirements Specification – Subset 026* - UNISIG
- [7] T. Gray, Publish and Flourish: *Write well and revise rapidly, Workshops by Gray* - She's anything but gray, New Mexico State University, 2003.
- [8] *Sistemi di controllo per l'alta velocità ferroviaria* – F. Flammini
- [9] <http://www.ertms.net/ertms/ertms-history.aspx>
- [10] <http://www.ertms.net/ertms/ertms-in-brief.aspx>
- [11] http://en.wikipedia.org/wiki/European_Train_Control_System
- [12] European Commision, Directorate General Transport - *European Rail Traffic Management System Requirement Specification* - bookshop.europa.eu/.../C30196341ENC_001.pdf
- [13] <http://www.irse.org.hk/eNewsletter/issue06/Technical-Articles/ETCS/ETCS.htm>
- [14] <http://www.therailengineer.com/2012/01/05/ertms-european-rail-traffic-management-system-in-operation/>
- [15] *INCREASE OF EFFICIENCY IN WIRELESS TRAIN CONTROL SYSTEMS (ETCS LEVEL 2) BY THE USE OF ACTUAL PACKET-ORIENTED TRANSMISSION CONCEPTS* - Simon F. Ruesche, Jan Steuer, Klaus Jobmann - Institute Communications Technology, Hannover (Germany), 2009
- [16] *Is GSM-R the limiting factor for the ERTMS system capacity?* – Gustaf Lindstrom (KTH) – Stockholm (Sweden), 2012
- [17] Kalden, R. A., 2004, "Mobile Internet Traffic Measurement and Modeling Based on Data from Commercial GPRS Networks", Wissenschaftsverlag Mainz, Aachen
- [18] http://en.wikipedia.org/wiki/GPRS_core_network

7. BIOGRAPHY



Maurizio Palumbo is the founder of railwaysignalling.eu, where he's also known as *Vesuvius*.

He was born in Naples, Italy, on 26 September 1986. He got , at the end of 2010, his degree in Computer Engineering from the University *Federico II* of Naples.

He's a curious, smiling and enthusiastic engineer.

Since the beginning of 2011 he has worked at Alstom Transport SPA in Bologna headquarter, as technical consultant for Alten, one of the European leaders in consulting and engineering. He has been involved in two ERTMS/ETCS L2 projects. In particular, he has specialized in the trackside subsystems, working both on Italian (Bologna-Florence High Speed Line) and Danish (Fjernbane East railway) projects.

APPENDIX A: MIGRATION FROM GSM-R to GPRS

Through a circuit switched connection there is a continuous channel set between the base station and the moving unit. This feature ensures a high QoS, but not a a very efficient usage of the connection, as the amount of data exchanged is rather low.

This is the reason why *GSM-R* has been considered in the last years as the *bottleneck* for the efficiency of the whole ERTMS system. A wide research work about a new technology to be applied for the transport issues related to the communication pushed all ERTMS stakeholders to consider the usage of a packet switched communication.

In this case, more than one user shares the same connection and the information transmitted is split up into packages sent each one after another, and only when there is a need for it by one of the user [16].

In public wireless networks the packet-switched General Packet Radio Service (GPRS) was used to increase the possibilities of the already existing wireless infrastructure. Currently the amount of data used for signalling within connection-oriented ETCS Level 2 environment is very small

and in most cases there are no transmissions for a long time interval. With GPRS the transmission channel is only used when data must be transmitted. Moreover, the connection establishment times are decreased, and the priority levels assigned to the data packets provide even more reliability regarding critical applications [17].

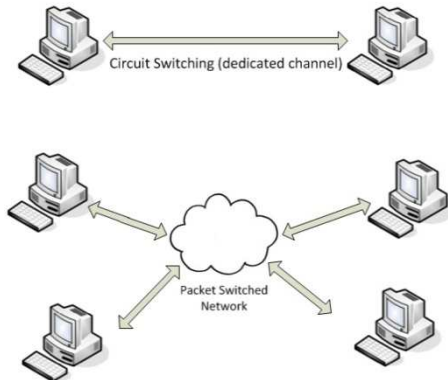

Figure 12 – Circuit Switching VS Packet Switching

The basic principle of the GPRS for railway application is building a data-oriented system which re-uses as much as possible of the existing voice-oriented system, GSM-R, and keeping its compatibility.

The major differences between a packet-oriented GPRS infrastructure and a connection-oriented GSM infrastructure consist in two further network elements:

- The *Serving GPRS Support Node (SGSN)* is responsible for the delivery of data packets from and to the mobile stations within its geographical service area. Its tasks include packet routing and transfer, mobility management (attach/detach and location management), logical link management, and authentication and charging functions.
- The *Gateway GPRS Support Node (GGSN)* acts as an interface between the GPRS backbone network and the external packet data networks. It converts the GPRS packets coming from the SGSN, mentioned before, into the appropriate Packet Data Protocol (PDP) format and sends them out on the corresponding packet data network. In the other direction, the addresses of incoming data packets are converted to the GSM address of the destination user. The re-addressed packets are sent to the responsible SGSN [18].

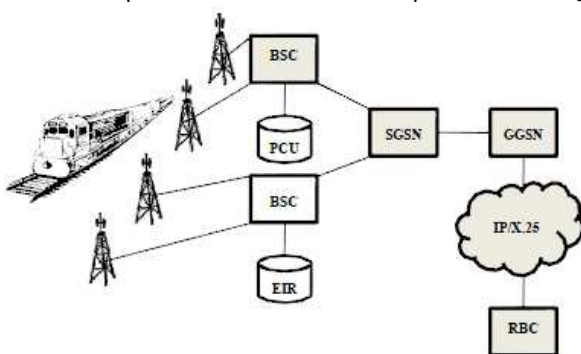

Figure 13 – GPRS-R simplified infrastructure

Once GPRS is activated, a virtual continuous connection between the network participants (e.g. train and RBC) is

established. During a session, a user is assigned to one pair of uplink and downlink frequency channels. This is combined with time domain statistical multiplexing, i.e. packet mode communication, which provides the common use of one frequency for several users. Only if information (e.g. ETCS telegrams) must be transmitted, the radio link will be reserved by a user [17].

Currently UNISIG consortium's working to standardize this technology as the ones chosen for ERTMS and next years all railway suppliers will realize ETCS lines equipped with GPRS-R network infrastructures.